

Y-4064

Genel Özellikler / General Specifications

Ölçü / Dimensions: 2" - 10"

Çalışma Sıcaklığı / Working Temperature: 0 ... 80 °C (16 Bar)

Standartlar / Standards

Tasarım / Design: TS EN 16767

Flanş Boyutları / Flange Dimensions: DIN EN 1092 PN10/PN16,
AS 2129TABLE E, JIS B2212 10K, BS 10TABLE D/E

Testler / Tests: TS EN 12266-1



Sistemdeki suyun tek yönlü olarak geçişine izin verir. Basınç kayıpları fazla olduğundan yangın tesisatlarında çok sayıda çek valf kullanılması istenmez.

Permits the flow of the fluid in only one direction. Due to the amount of pressure losses the use of multiple check valves is rather not requested in fire protection systems.

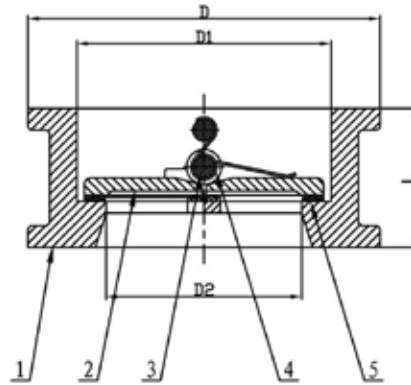

Malzeme Özellikleri Material Specifications

No	Parça Adı/Part Name	Malzeme/Material
1	Gövde/Body	EN-GJS-450-10
2	Klape/Disc	EN-GJS-450-10
3	Mil/Stem	SS420
4	Yay/Spring	SS304
5	Sit/Seat	EPDM



Ölçüler Dimension

PN	300 psi (21 bar)			
	L	D	D1	D2
50	54	107	64	46
65	54	127	78	60
80	57	142	94	70
100	64	162	117	84
125	70	192	145	115
150	76	218	170	134
200	95	273	224	184
250	108	328	265	220